

Diamond Napkin Ring Templates

Materials (per napkin ring)

Two 3.75" x 2.5" rectangles of fabric
24" ribbon

Directions

1. Cut two pieces of fabric to the size of the template. One will be the back and one will be the front.

If you feel comfortable sewing $1/8$ " seams, you can use the smaller template, which requires 3.5" x 2.25" rectangles instead.

2. Place pieces right-sides together and stitch all the way around using the specified seam allowance, except between the dots. Trim seam allowance to $1/8$ " if using larger template.

Make sure to anchor or backstitch at dots so seams don't loosen when you turn the unit right-side out.

3. Turn the unit right-side out. Press, making sure to keep the seam allowance between the dots folded in.

A point turner or chopstick works wonders for this step, helping push the points out and creasing the seam allowance at the opening.

4. Topstitch around the edge approximately $1/16$ " from the edge. Be sure to catch seam allowance at the opening to close it.

You can whipstitch the opening closed if you prefer not to have the topstitched look.

5. Align center of ribbon to center of fabric piece and secure with regular or decorative stitching, leaving $1/2$ " on each side of fabric piece loose.

6. Admire your napkin ring!

This square
should measure
1"
when printed

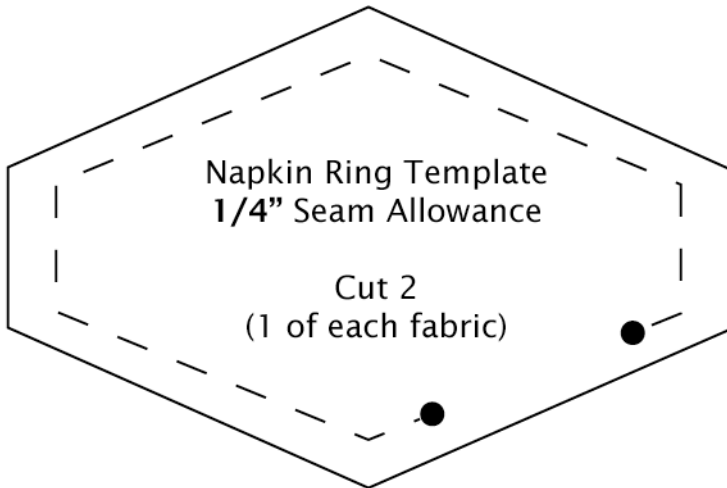

— or —

